

# DB4055, DB4056, DB4067, DB4068, DB4071, DB4072

## Rack Mount Duplexers

### Installation and Tuning Instructions

#### PRODUCT DESCRIPTION

**DB4055** - The DB4055 duplexer is designed for use with a single, broad band antenna in a mobile repeater or duplex-type system. It operates in the 150 to 174 MHz band when the transmitter and receiver frequencies are separated by 5 MHz or more. Five sealed quarter-wave helical resonators are interconnected in a band-reject configuration with double-shielded coaxial cable to provide 75 dB rejection (nominal) to transmitter noise and 75 dB isolation (nominal) to receiver desensitization. The 150 to 174 MHz band is covered in two sub-bands: 150 to 162 MHz and 160 to 174 MHz.

**DB4056** - The DB4056 duplexer is similar to the DB4055. It includes six helical resonators and is designed for use in systems having only 2 to 5 MHz separating the transmit and receive frequencies.

**DB4067 and DB4068** - The DB4067 and DB4068 duplexers are designed for use in the 406 to 420 MHz band. The DB4067 consists of four quarter-wave coaxial cavities that are interconnected in a band-reject configuration. They use double-shielded coaxial cable and provide a minimum of 55 dB isolation between the transmitter and receiver. The DB4068 has two additional quarter-wave coaxial cavities which increase its isolation to a minimum of 75 dB.

**DB4071** - The DB4071 duplexer is designed for use with systems in the 450 to 470 MHz band with a frequency separation of 5 MHz or more. It consists of four quarter-wave coaxial cavities that are interconnected in a band-reject configuration with double-shielded cable. They provide a minimum of 55 dB isolation between the transmitter and receiver, which typically exceeds normal requirements at this frequency spacing.

**DB4072** - The DB-4072 is a six-cavity version of the DB4071. It provides significantly greater overall isolation between the transmitter and receiver and is primarily designed for use in systems with a frequency separation of 2.75 to 5 MHz, although it can be used outside these limits.

#### INSTALLATION PROCEDURE

The rack-mounted duplexers can be mounted vertically or horizontally in most standard 19-inch rack mount stations or on any flat surface. The multi-position mounting bracket permits mounting of the unit either in-line with the other chassis or to the front, back, or center of the 19-inch cabinet rack. The mounting bracket is easily installed using the self-tapping screws (see Figure 1).

Important: To maintain maximum isolation, use double-shielded or solid outer conductor coaxial cable from the duplexer to the transmitter and receiver chassis.

#### FIELD TUNING

The duplexers are factory-tuned to the exact operating frequencies and shipped ready for immediate installation. No further field tuning or adjustment is required. If it becomes necessary to change

the operating frequencies of a duplexer, it may be returned to the factory for retuning or it can be field-tuned if the following equipment is available:

1. A signal generator (50 ohms) capable of producing a signal at the transmitter and receiver frequencies.
2. A receiver tuned to the desired receiver frequency.
3. A receiver tuned to the desired transmitter frequency.
4. Two 50 ohm pads.

#### FIELD TUNING PROCEDURE

1. Connect the equipment as shown in Figure 2a. (If the receivers are not 50 ohms, place 50 ohm pads as shown in the illustration.)
2. Refer to Figure 3 and locate the transmitter and receiver cavities within the duplexer.
3. Tune the signal generator to the desired transmitter frequency. Tune each receiver cavity for a *minimum* signal into receiver #1. (Turn the tuning screw clockwise to decrease the resonant frequency of the cavity.)
4. Tighten and lock the tuning screw shaft nut after tuning each cavity.
5. Tune the signal generator to the desired receiver frequency. Tune each transmitter cavity for a minimum signal into receiver #2.

#### LABORATORY TUNING PROCEDURE

1. Connect the equipment as shown in Figure 2b.
2. Connect the 3 dB pads to the antenna and receiver terminals on the duplexer.
3. Place a 50 ohm load on the duplexer's transmitter terminal.
4. While observing the frequency counter, tune the signal generator to within 1 KHz of the transmitter frequency.
5. Tune the local oscillator 30 MHz below the transmitter frequency to obtain a reading on the 30 MHz I.F. amplifier. Add or remove attenuation with the decade attenuators until the I.F. amplifier reads on scale.
6. See Figure 3 for the location of the transmitter and receiver cavities within the duplexer.
7. Tune each receiver cavity for a minimum signal into the I.F. amplifier. (Turn the tuning screw clockwise to lower the resonant frequency of cavity.)
8. Set the reference reading on the I.F. amplifier meter and note the attenuation in decade attenuators.

*Continued on page 2*



- Remove the duplexer from the equipment setup and connect the 3dB pads together. Add attenuation in the decade attenuators until the reference reading on the I.F. amplifier is achieved. The difference between the decade attenuation readings from Step 8 is the amount of isolation through the duplexer at the transmitter frequency.
- Repeat Steps 4 through 10 at the receiver frequency and connect the pads to the antenna and transmitter terminals with a 50 ohm load on the receiver terminal. Tune the transmitter

- cavities for a minimum signal to the I.F. amplifier.
- Lock the tuning screw shaft after tuning each cavity.
- With test equipment tuned to the transmitter frequency, measure insertion loss between the receiver and antenna terminals.
- With the test equipment tuned to the receiver frequency, measure the insertion loss between the receiver and antenna terminals.

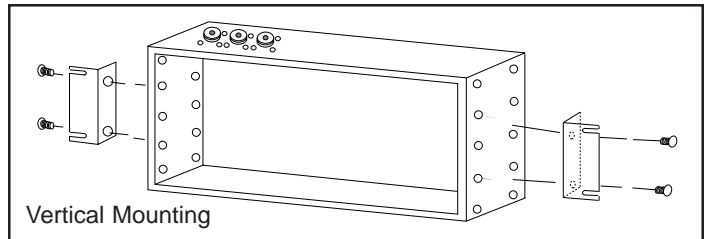
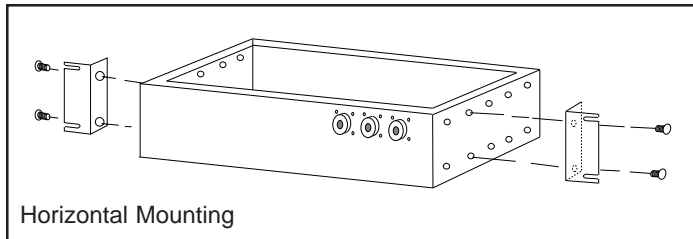

Figure 1 - Horizontal and Vertical Mounting

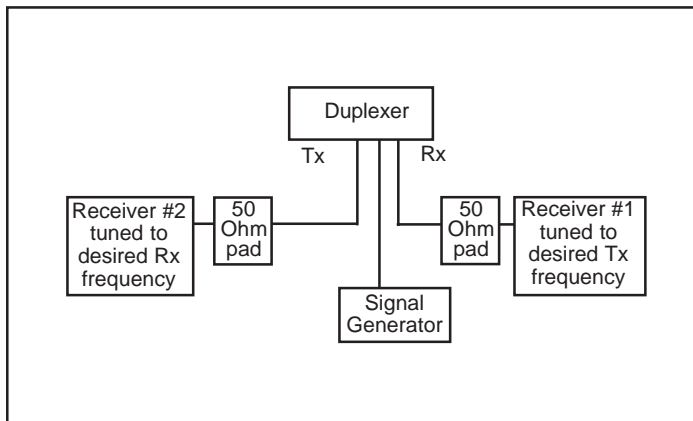

Figure 2a: Field Tuning Equipment

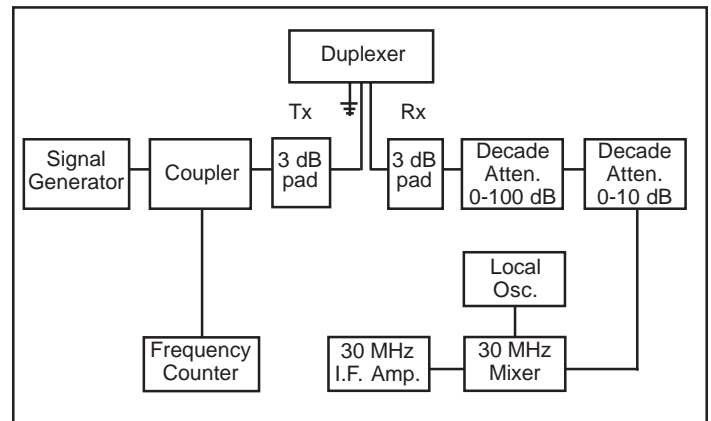

Figure 2b: Laboratory Tuning Equipment

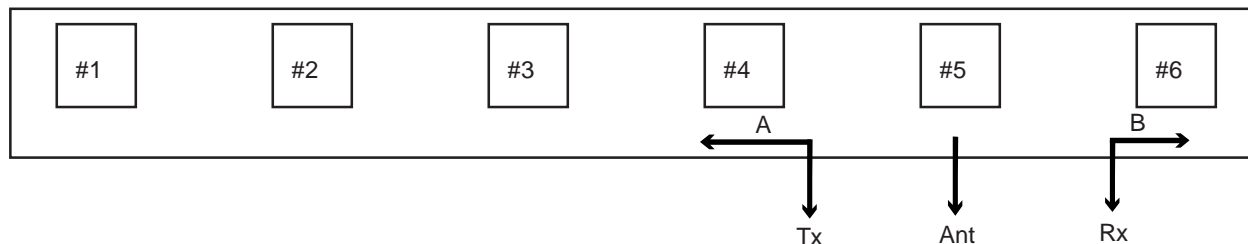

Figure 3 - Duplexer Layout

	DB4055		DB4056		DB4067 / 4071		DB4068 / 4072	
	Tx Cavity	Rx Cavity	Tx Cavity	Rx Cavity	Tx Cavity	Rx Cavity	Tx Cavity	Rx Cavity
Tx frequency less than Rx	1, 2	3, 4, 5	1, 2, 3	4, 5, 6	2, 3	4, 5	1, 2, 3	4, 5, 6
Tx frequency greater than Rx	3, 4, 5	1, 2	4, 5, 6	1, 2, 3	4, 5	2, 3	4, 5, 6	1, 2, 3

Note: Layouts shown are for situations in which the Tx frequency is less than the Rx frequency. If the Tx frequency is greater than the Rx frequency, cables A and B should be interchanged on each unit.

